

# JC SYSTEMS by TMC Services

## A2298-1 SINGLE FAST ANALOG OUTPUT BOARD (SYNC)

### FAST ANALOG BOARD HOOK-UP:

Connect 115VAC to TB5

Connect Ribbon Cable K1292 from P1 on the A2298 Bd. To P3 on the A2225 Output Interface Board of the Model 620A/600A.

Connect the 4-20mA (0-16mA) output from TB4-1 (-) & TB4-2 (+) on the A2298 Board to the device to be controlled.

**S1 (4-20mA/ 0-16mA selection)** - Install jumper for 4-20mA. Remove jumper 0-16mA operation.

**FAST ANALOG OPERATION:** The A2298 Fast analog board can be controlled from either CH1 or CH2 of the Model 620A/600A. However, the OUTPUT CURRENT LOOP 1 of the unit must be assigned to the desired channel for proper operation.

### OUTPUT CURRENT LOOP 1 CONFIGURATION: (Model 620A/600A):

From the Main Menu -      Select Item # 4 (CONFIG.-TUNE-CALIB)  
                                  Select Item # 2 ((CONFIG. CNTRLS/TUNE)  
                                  Select Item # 1 (CONFIGURE CHANNEL 1)

Push the Page Down button to the OUTPUT CURRENT LOOP 1 screen.

Push the SEL button to select the CH to control the A2298 board (CH 1 or CH 2)

Push DOWN ARROW button: Selecting 4-20mA or 0-16mA will have no effect on the A2298 board. The A2298 Output is selected using S1 on the A2298 board.

Push DOWN ARROW button: Use SEL button to scroll through the choices for the desired control action the A2298 board will produce. The choices are:

DIRECT ACTING - Decrease action (cooling, dehumidification, etc.)

REVERSE ACTING - Increase action (heating, humidification, etc.)

12MA NULL - 12mA = Null. 12mA to 20mA = 0-100% INC., 12mA to 4mA = 0-100% DEC.

SETPOINT RETRANSMIT & PROCESS RETRANSMIT - Retransmits Setpoint or Process value based on the selected CH units (deg C, deg. F, %RH, etc.) and the selected Span of the CH.

DUAL ACTING - Not Used. Used for operating the A2336 Dual Fast Analog Board.

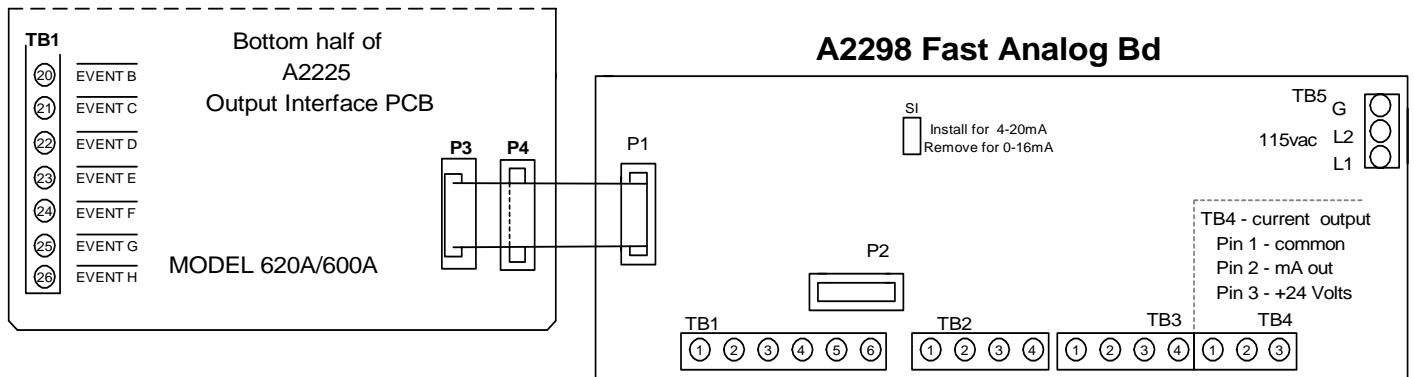

# Synchronizing two Model 620A/600A's, using the A2298 Single Fast Analog Bd.

*JC SYSTEMS by TMC Services Inc.*  
 P.O. Box 157  
 Elk River, MN 55330  
 Ph: (763)-241-1456 Fax: (763)-241-1829  
 Email: jcsystems@tmcservices.net  
 Web: www.jcsystemsinc.com

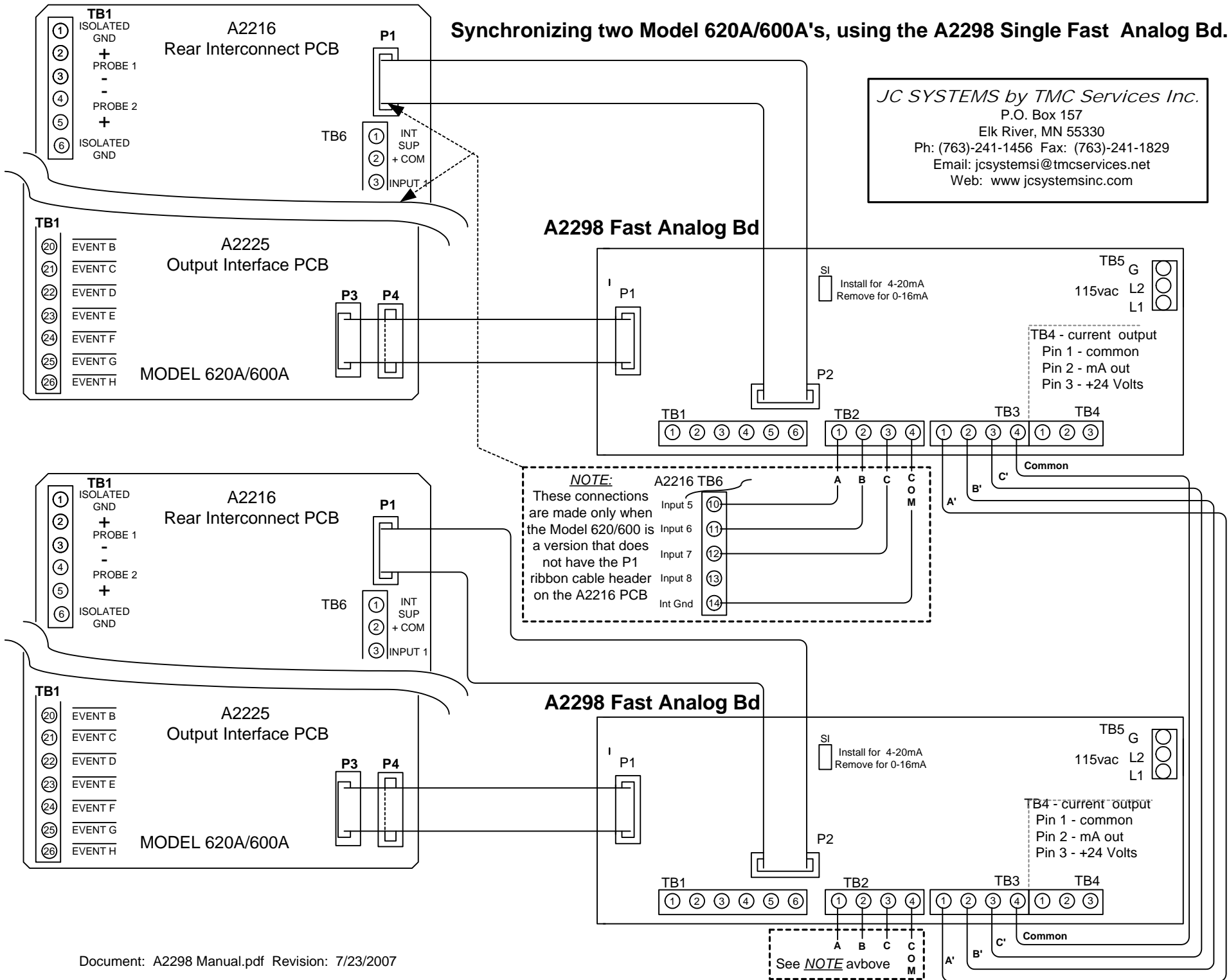

## JC Systems A2298-1 Fast Analog Bd Output Calibration.

The chamber heat /cool outputs must be disabled during this procedure.  
Remove the wires from TB4-1 (Common) and -2 (mA out).  
Connect a mA meter to TB4-1 - (neg) and TB4-2 + (plus).

- 1 - Enter a setpoint on the Model 600A/620A that provides 0.0% output from the A2298 board.
- 2 - Adjust pots R2, R8, R11 & R13 fully CCW.
- 3 - Remove jumpers on S1 & S2.
- 4 - Adjust Balance pot (R11) for a meter reading of 0.0001mA.
- 5 - Install jumper on S1.
- 6 - Adjust 4mA pot (R8) for a reading of 4.000mA.
- 7 - Disconnect ribbon cable from P1, and allow the output to settle.
- 8 - Adjust Slope pot (R13) for a meter reading of 20.000mA.
- 9 - Reconnect the ribbon cable to P1.

Repeat steps 6 - 9 until both readings are +/- 0.001mA  
Calibration is complete.

NOTE: The Slew Pot (R13) is left in the full CCW position and the jumper remains OFF (or switch UP).

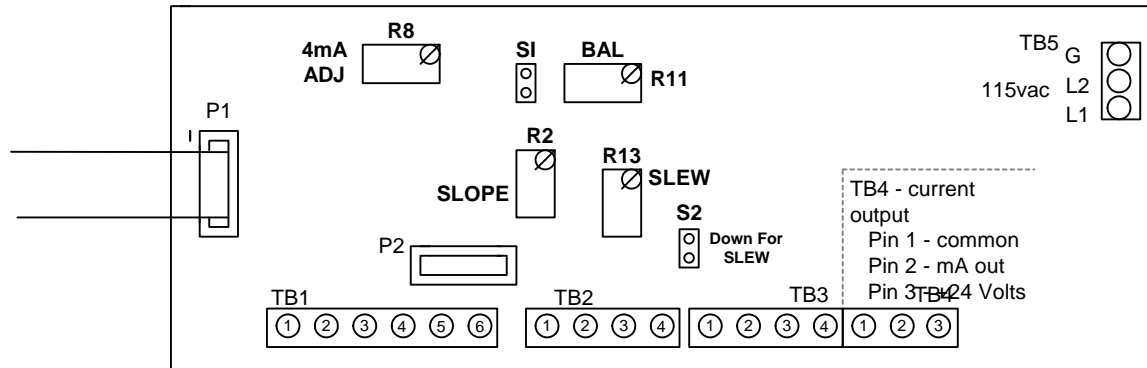

S1 - Install for 4-20mA (Jumper ON)  
Remove for 0-16mA (Jumper OFF)

S2 - Down for Slew (Jumper ON)  
Up Slew disabled (Jumper OFF) - Factory default  
Note: The Slew function should not be enabled.  
Jumper should be off (or switch in up position).  
R13 should be adjusted full CCW

R8 - 4mA adjustment Pot.

R11 - Zero Balance Pot.

R2 - Slope (20mA) adjustment pot.

R13 - Slew adjustment pot.

Note: The Slew function should not be enabled.  
R13 should be adjusted full CCW.  
Jumper should be off, (or switch in up position).

*JC SYSTEMS by TMC Services Inc.*  
P.O. Box 157  
Elk River, MN 55330  
Ph: (763)-241-1456 Fax: (763)-241-1829  
Email: jcsystems@tmcservices.net  
Web: www.jcsystemsinc.com

## A2298 Single Fast Analog Board Resistor values for Voltage output.

Rx1, Rx2 & Rx5 are parallell resistors.

Rx3 & Rx4 are series resistors in parallell with Rx1, 2 &5.

For voltage outputs install the resistors as shown:

1V. R1 - 63.4 ohms & R2 - 4.42K ohms.

5V. R3 - 301 ohms & R4 - 11.5 ohms.

10V. R1 625 ohms.



For outputs of 0-1v, 0-5v or 0-10v remove jumper on S1 or pull switch S1 into the Up position.